

Silicon NPN Power Transistors

BUT18F BUT18AF

DESCRIPTION

- With TO-220Fa package
- High voltage ,high speed

APPLICATIONS

- Converters
- Inverters
- Switching regulators
- Motor control systems

PINNING

PIN	DESCRIPTION
1	Base
2	Collector
3	Emitter

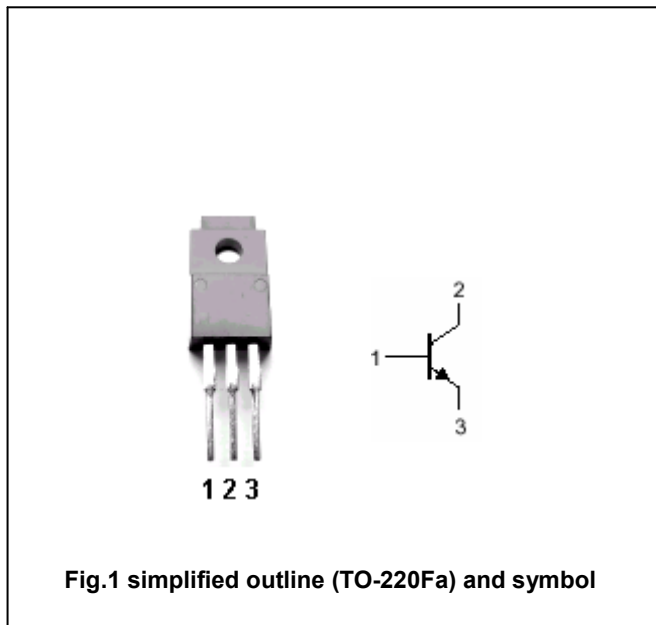

Absolute maximum ratings (Tc=25°C)

SYMBOL	PARAMETER	CONDITIONS	VALUE	UNIT
V _{CBO}	Collector-base voltage	BUT18F	850	V
		BUT18AF	1000	
V _{CEO}	Collector-emitter voltage	BUT18F	400	V
		BUT18AF	450	
V _{EBO}	Emitter-base voltage	Open collector	9	V
I _C	Collector current		6	A
I _{CM}	Collector current-peak		12	A
I _B	Base current		3	A
I _{BM}	Base current-peak		6	A
P _{tot}	Total power dissipation	T _c =25°C	33	W
T _j	Junction temperature		150	°C
T _{stg}	Storage temperature		-65~150	°C

Silicon NPN Power Transistors

BUT18F BUT18AF

CHARACTERISTICS

T_j=25 °C unless otherwise specified

SYMBOL	PARAMETER		CONDITIONS	MIN	TYP.	MAX	UNIT
V _{CEO(SUS)}	Collector-emitter sustaining voltage	BUT18F	I _C =0.1A; I _B =0; L=25mH	400			V
		BUT18AF		450			
V _{CEsat}	Collector-emitter saturation voltage		I _C =4A; I _B =0.8A			1.5	V
V _{BEsat}	Base-emitter saturation voltage		I _C =4A; I _B =0.8A			1.3	V
I _{CES}	Collector cut-off current	BUT18F	V _{CE} =850V; V _{BE} =0 T _j =125 °C			1.0 2.0	mA
		BUT18AF	V _{CE} =1000V; V _{BE} =0 T _j =125 °C			1.0 2.0	
I _{EBO}	Emitter cut-off current		V _{EB} =9V; I _C =0			10	mA
h _{FE-1}	DC current gain		I _C =10mA; V _{CE} =5V	10		35	
h _{FE-2}	DC current gain		I _C =1A; V _{CE} =5V	10		35	

Switching times resistive load

t _{on}	Turn-on time	I _C =4A; I _{B1} =-I _{B2} =0.8A V _{CC} =250V			1.0	μs
t _s	Storage time				4.0	μs
t _f	Fall time				0.8	μs

Silicon NPN Power Transistors

BUT18F BUT18AF

PACKAGE OUTLINE

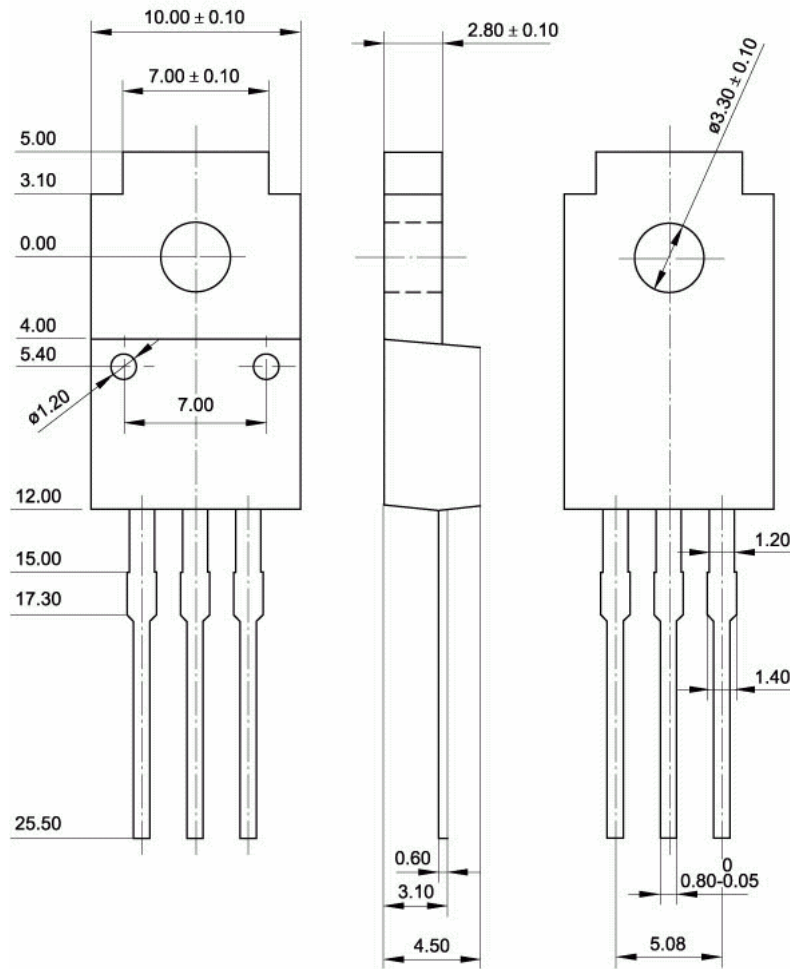

Fig.2 Outline dimensions (unindicated tolerance: ± 0.15 mm)