

Silicon PNP Power Transistors

BD434/436/438

DESCRIPTION

- With TO-126 package
- Complement to type BD433/435/437

APPLICATIONS

- For medium power linear and switching applications

PINNING

PIN	DESCRIPTION
1	Emitter
2	Collector;connected to mounting base
3	Base

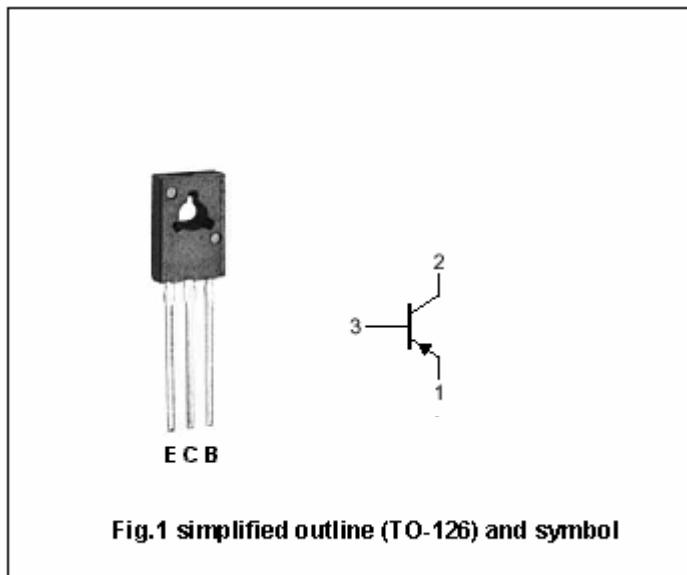

Absolute maximum ratings (Ta=25°C)

SYMBOL	PARAMETER	CONDITIONS	VALUE	UNIT
V _{CBO}	Collector-base voltage	BD434	-22	V
		BD436	-32	
		BD438	-45	
V _{CEO}	Collector-emitter voltage	BD434	-22	V
		BD436	-32	
		BD438	-45	
V _{EBO}	Emitter -base voltage	Open collector	-5	V
I _C	Collector current (DC)		-4	A
I _{CM}	Collector current-Peak		-7	A
I _B	Base current		-1	A
P _C	Collector power dissipation	T _C =25°C	36	W
T _j	Junction temperature		150	°C
T _{stg}	Storage temperature		-65~150	°C

Silicon PNP Power Transistors

BD434/436/438

CHARACTERISTICS

T_j=25 °C unless otherwise specified

SYMBOL	PARAMETER		CONDITIONS	MIN	TYP.	MAX	UNIT
V _{CEsat}	Collector-emitter saturation voltage	BD434/436	I _C =-2A; I _B =-0.2A		-0.2	-0.5	V
		BD438				-0.6	
V _{BE}	Base-emitter on voltage	BD434/436	I _C =-2A; V _{CE} =-1V			-1.1	V
		BD438				-1.2	
V _{CEO(SUS)}	Collector-emitter sustaining voltage	BD434	I _C =-0.1A; I _B =0			-22	V
		BD436				-32	
		BD438				-45	
I _{CES}	Collector cut-off current	BD434	V _{CB} =-22V; I _E =0			-100	μA
		BD436	V _{CB} =-32V; I _E =0				
		BD438	V _{CB} =-45V; I _E =0				
I _{CES}	Collector cut-off current	BD434	V _{CE} =-22V; V _{BE} =0			-100	μA
		BD436	V _{CE} =-32V; V _{BE} =0				
		BD438	V _{CE} =-45V; V _{BE} =0				
I _{EBO}	Emitter cut-off current		V _{EB} =-5V; I _C =0			-1	mA
h _{FE-1}	DC current gain	BD434/436	I _C =-10mA; V _{CE} =-5V			130	
		BD438					
h _{FE-2}	DC current gain		I _C =-0.5A; V _{CE} =-1V			85	140
h _{FE-3}	DC current gain	BD434/436	I _C =-2A; V _{CE} =-1V				50
		BD438					40
f _T	Transition frequency		I _C =-250mA; V _{CE} =-1V			3	MHz

Silicon PNP Power Transistors

BD434/436/438

PACKAGE OUTLINE

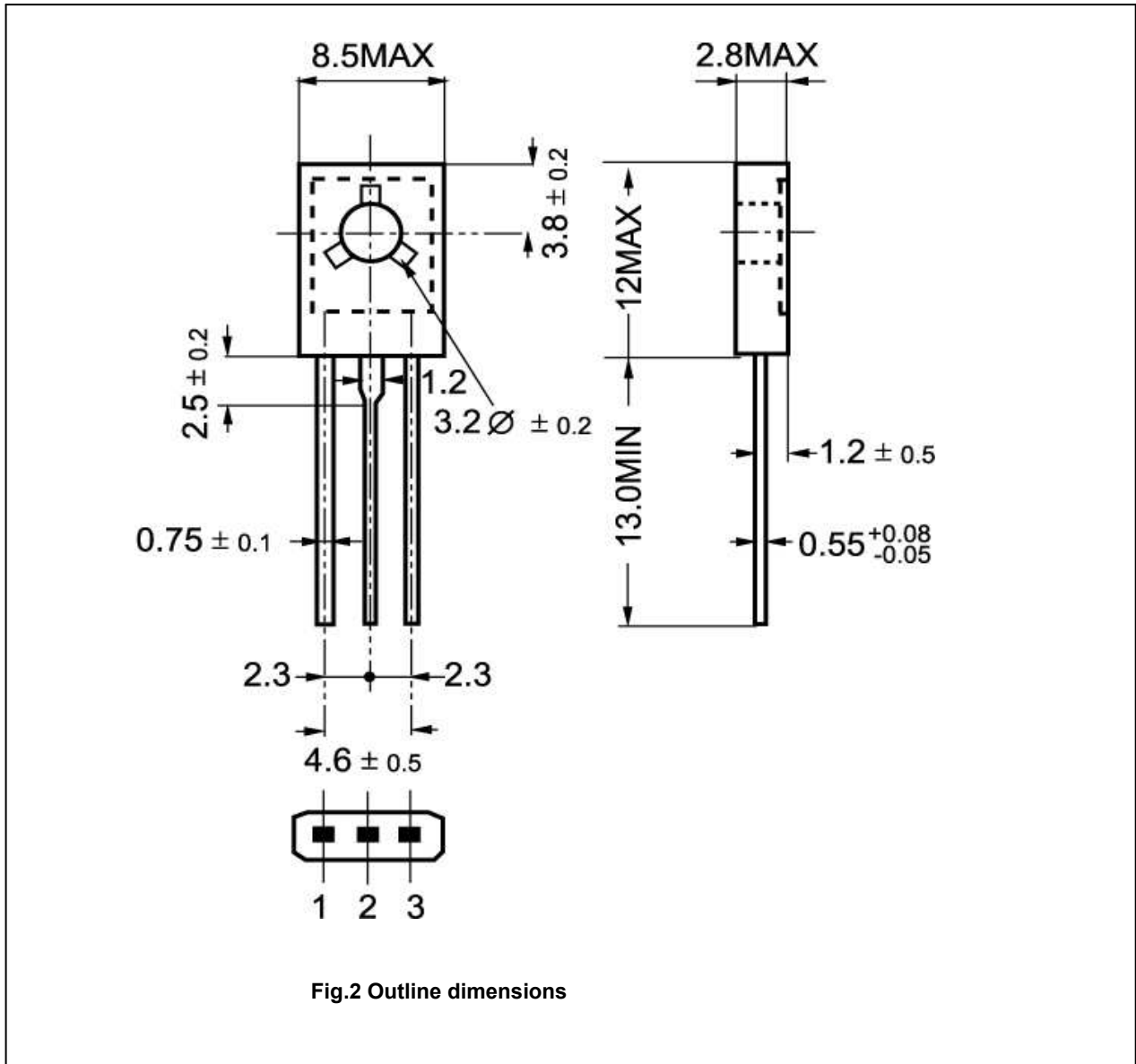

This datasheet has been downloaded from:

www.DatasheetCatalog.com

Datasheets for electronic components.