

**Silicon NPN Power Transistors**

**2SD985 2SD986**

**DESCRIPTION**

- With TO-126 package
- Complement to type 2SB794/795
- DARLINGTON
- High DC current gain
- Low collector saturation voltage

**APPLICATIONS**

- For low frequency power amplifier and power switching applications

**PINNING**

PIN	DESCRIPTION
1	Emitter
2	Collector;connected to mounting base
3	Base

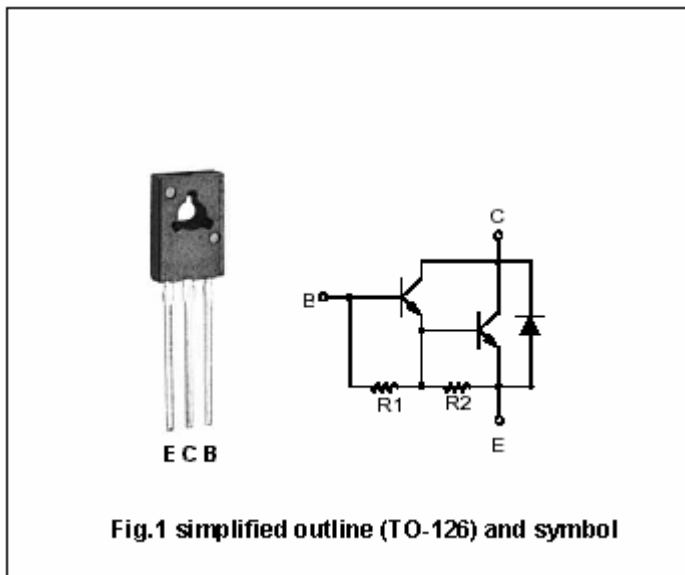

**Absolute maximum ratings (Ta=25°C)**

SYMBOL	PARAMETER	CONDITIONS	VALUE	UNIT
V <sub>CBO</sub>	Collector-base voltage	Open emitter	150	V
V <sub>CEO</sub>	Collector-emitter voltage	2SD985	60	V
		2SD986	80	
V <sub>EBO</sub>	Emitter -base voltage	Open collector	8	V
I <sub>C</sub>	Collector current		±1.5	A
I <sub>CM</sub>	Collector current-Peak		±3.0	A
I <sub>B</sub>	Base current		0.15	A
P <sub>T</sub>	Total power dissipation	T <sub>a</sub> =25°C	1.0	W
		T <sub>C</sub> =25°C	10	
T <sub>J</sub>	Junction temperature		150	°C
T <sub>stg</sub>	Storage temperature		-55~150	°C

## Silicon NPN Power Transistors

## 2SD985 2SD986

## CHARACTERISTICS

T<sub>j</sub>=25°C unless otherwise specified

SYMBOL	PARAMETER		CONDITIONS	MIN	TYP.	MAX	UNIT
V <sub>CEsat</sub>	Collector-emitter saturation voltage		I <sub>C</sub> =1.0A; I <sub>B</sub> =1.0mA			1.5	V
V <sub>BEsat</sub>	Base-emitter saturation voltage		I <sub>C</sub> =1.0A; I <sub>B</sub> =1.0mA			2.0	V
I <sub>CBO</sub>	Collector cut-off current	2SD985	V <sub>CB</sub> =60V; I <sub>E</sub> =0			10	μA
		2SD986	V <sub>CB</sub> =80V; I <sub>E</sub> =0				
I <sub>EBO</sub>	Emitter cut-off current		V <sub>EB</sub> =5V; I <sub>C</sub> =0			2.0	mA
h <sub>FE-1</sub>	DC current gain		I <sub>C</sub> =0.5A; V <sub>CE</sub> =2V	1000			
h <sub>FE-2</sub>	DC current gain		I <sub>C</sub> =1.0A; V <sub>CE</sub> =2V	2000		30000	

## Switching times

t <sub>on</sub>	Turn-on time	I <sub>C</sub> =1.0A; I <sub>B1</sub> =-I <sub>B2</sub> =1.0mA V <sub>CC</sub> =50V; R <sub>L</sub> =50Ω		0.5		μs
t <sub>s</sub>	Storage time			1.0		μs
t <sub>f</sub>	Fall time			1.0		μs

◆ h<sub>FE-2</sub> Classifications

M	L	K
2000-5000	4000-10000	8000-30000

Silicon NPN Power Transistors

2SD985 2SD986

PACKAGE OUTLINE

