

Silicon NPN Power Transistors

2SC4236

DESCRIPTION

- With TO-247 package
- Switching power transistor
- High breakdown voltage

PINNING

PIN	DESCRIPTION
1	Base
2	Collector;connected to mounting base
3	Emitter

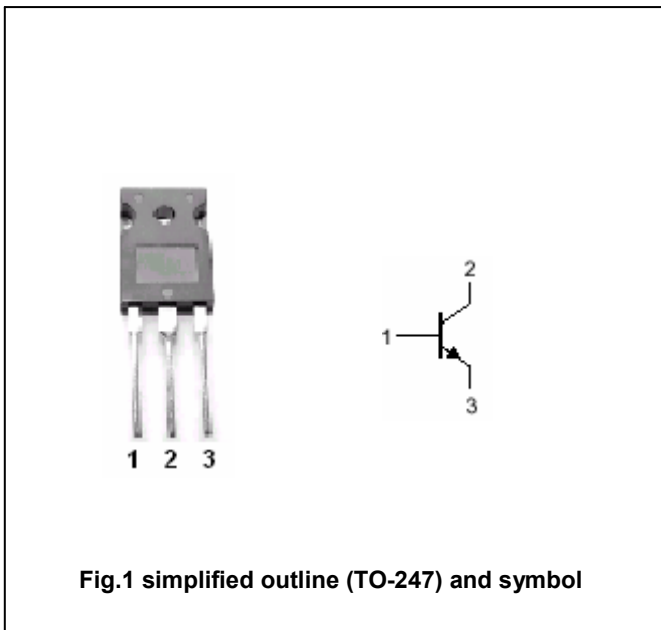

Fig.1 simplified outline (TO-247) and symbol

Absolute maximum ratings(Tc=25°C)

SYMBOL	PARAMETER	CONDITIONS	VALUE	UNIT
V _{CBO}	Collector-base voltage	Open emitter	1200	V
V _{CEO}	Collector-emitter voltage	Open base	800	V
V _{EBO}	Emitter-base voltage	Open collector	7	V
I _C	Collector current (DC)		6	A
I _{CM}	Collector current-Peak		12	A
I _B	Base current		3	A
I _{BM}	Base current-Peak		6	A
P _D	Total power dissipation	T _c =25°C	100	W
T _j	Junction temperature		150	°C
T _{stg}	Storage temperature		-55~150	°C

THERMAL CHARACTERISTICS

SYMBOL	PARAMETER	MAX	UNIT
R _{th j-c}	Thermal resistance junction to case	1.25	°C/W

Silicon NPN Power Transistors

2SC4236

CHARACTERISTICS

T_j=25°C unless otherwise specified

SYMBOL	PARAMETER	CONDITIONS	MIN	TYP.	MAX	UNIT
V _{CE0(SUS)}	Collector-emitter sustaining voltage	I _C =0.2A; I _B =0	800			V
V _{CEsat}	Collector-emitter saturation voltage	I _C =3A; I _B =0.6A			1.0	V
V _{BEsat}	Base-emitter saturation voltage	I _C =3A; I _B =0.6A			1.5	V
I _{CBO}	Collector cut-off current	At rated voltage			0.1	mA
I _{CEO}	Collector cut-off current					
I _{EBO}	Emitter cut-off current	At rated voltage			0.1	mA
h _{FE-1}	DC current gain	I _C =3A; V _{CE} =5V	8			
h _{FE-2}	DC current gain	I _C =1mA; V _{CE} =5V	7			
f _T	Transition frequency	I _C =0.6A; V _{CE} =10V		8		MHz

Switching times resistive load

t _{on}	Turn-on time	I _C =3A I _{B1} =0.6A; I _{B2} =1.2A V _{BB2} =4V, R _L =85Ω			0.5	μs
t _s	Storage time				3.5	μs
t _f	Fall time				0.3	μs

Silicon NPN Power Transistors

2SC4236

PACKAGE OUTLINE

