

Silicon NPN Power Transistors

2SC4123

DESCRIPTION

- With TO-3PML package
- High breakdown voltage, high reliability.
- High speed
- Built in damper diode

APPLICATIONS

- Ultrahigh-definition CRT display
- Horizontal deflection output applications

PINNING

PIN	DESCRIPTION
1	Base
2	Collector
3	Emitter

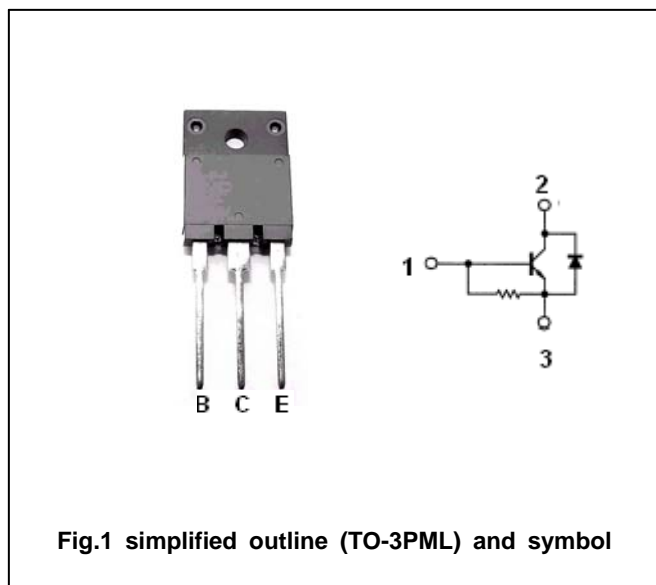

Maximum absolute ratings(Ta=25°C)

SYMBOL	PARAMETER	CONDITIONS	VALUE	UNIT
V_{CBO}	Collector-base voltage	Open emitter	1500	V
V_{CEO}	Collector-emitter voltage	Open base	800	V
V_{EBO}	Emitter-base voltage	Open collector	6	V
I_C	Collector current		7	A
I_{CM}	Collector current-peak		16	A
P_C	Collector power dissipation	$T_c=25^\circ\text{C}$	60	W
			3	W
T_j	Junction temperature		150	°C
T_{stg}	Storage temperature		-55~150	°C

Silicon NPN Power Transistors

2SC4123

CHARACTERISTICS

T_j=25°C unless otherwise specified

SYMBOL	PARAMETER	CONDITIONS	MIN	TYP.	MAX	UNIT
V _{CEsat}	Collector-emitter saturation voltage	I _C =5A; I _B =1.2 A			5	V
V _{BEsat}	Base-emitter saturation voltage	I _C =5A; I _B =1.2 A			1.5	V
V _{CEO(SUS)}	Collector-emitter sustaining voltage	I _C =100mA; I _B =0	800			V
I _{EBO}	Emitter cut-off current	V _{EB} =4V; I _C =0	40		130	mA
I _{CBO}	Collector cut-off current	V _{CB} =800V; I _E =0			10	μ A
I _{CES}	Collector cut-off current	V _{CE} =1500V; R _{BE} =0			1	mA
h _{FE-1}	DC current gain	I _C =1 A ; V _{CE} =5V	8			
h _{FE-2}	DC current gain	I _C =5A ; V _{CE} =5V	4		6	
V _F	Diode forward voltage	I _{EC} =7A			2.0	V

Switching times

t _{stg}	Storage time	I _C =5A; R _L =33.3 Ω I _{B1} =1A; - I _{B2} =2A V _{CC} =200V			3.0	μ s
t _f	Fall time			0.1	0.2	μ s

Silicon NPN Power Transistors

2SC4123

PACKAGE OUTLINE

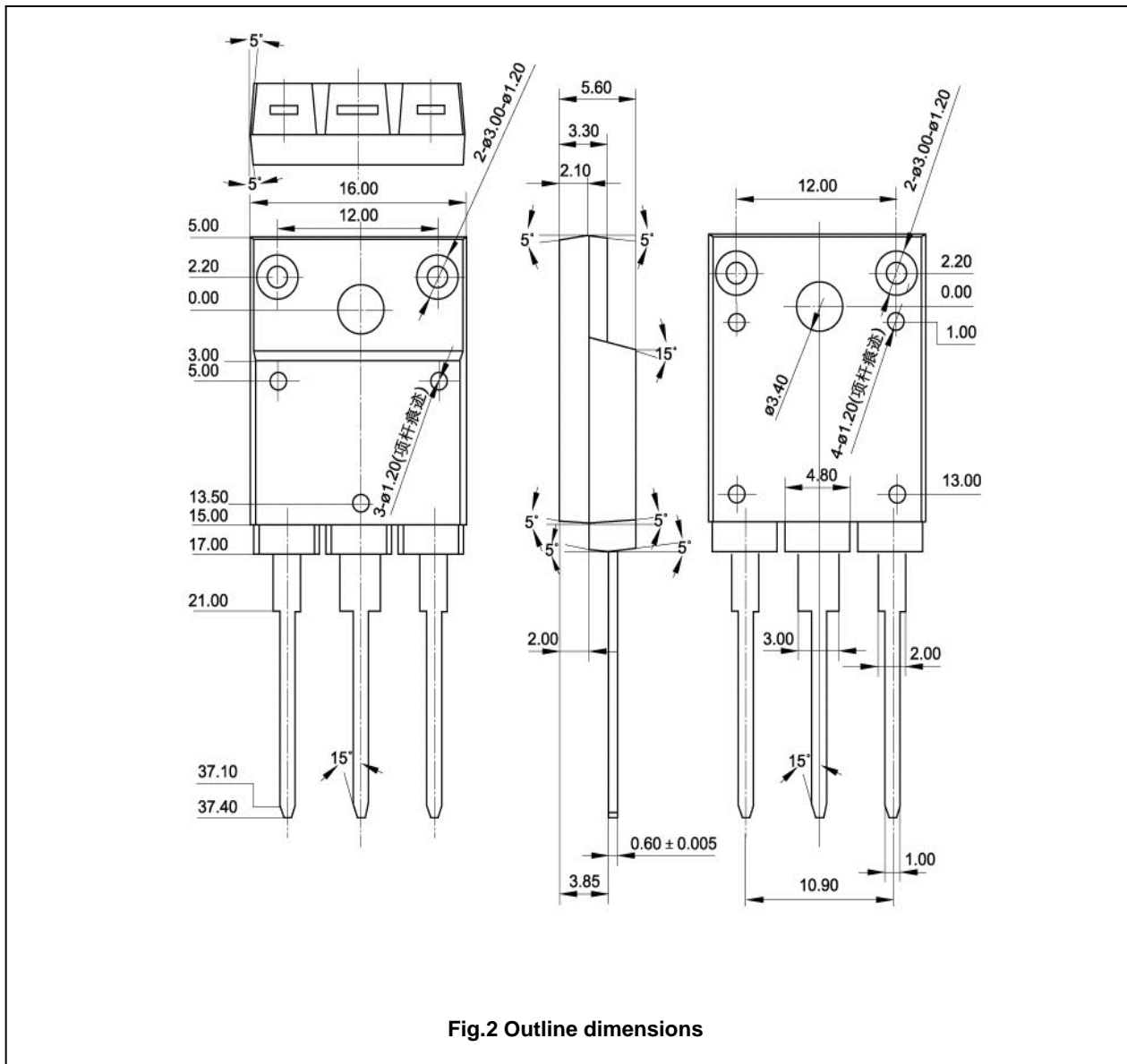

Silicon NPN Power Transistors

2SC4123

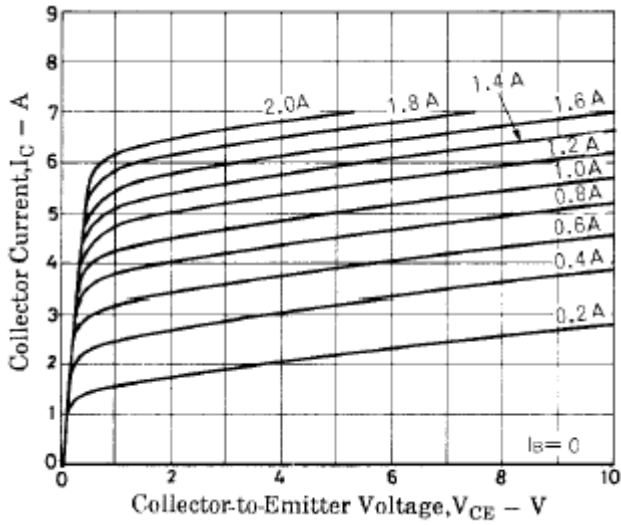

Fig.3 Static Characteristic

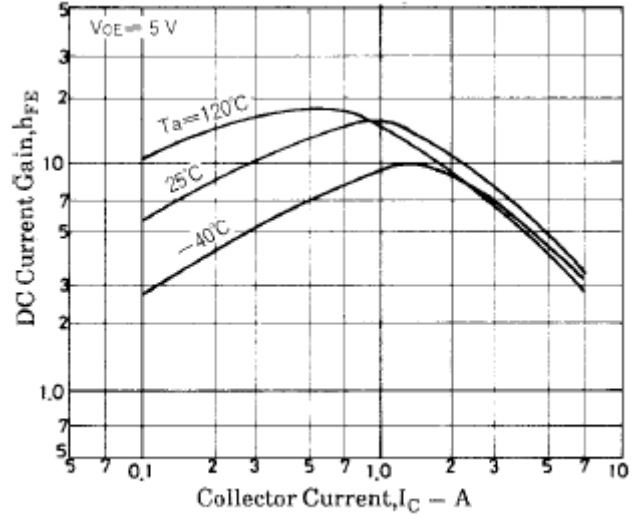

Fig.4 DC current Gain

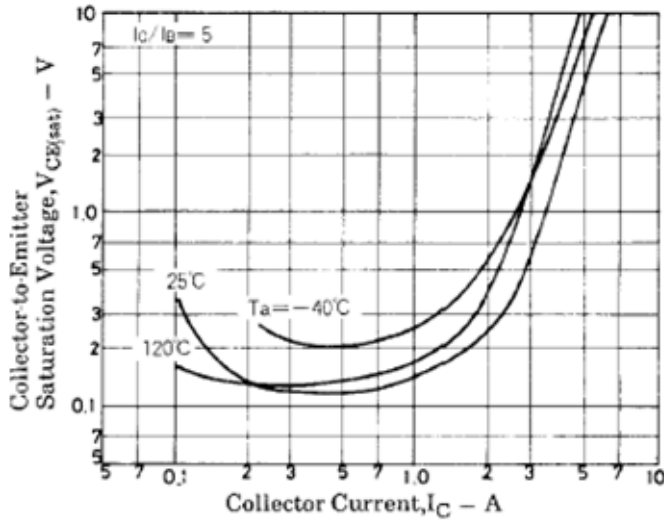

Fig.5 Collector-Emitter Saturation Voltage

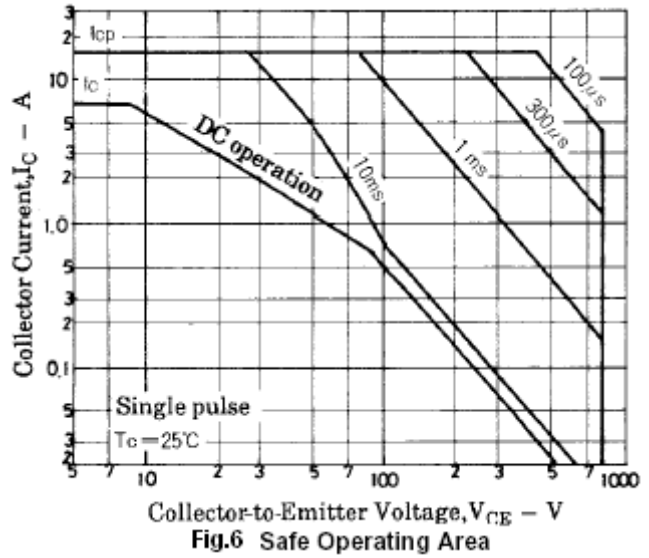

Fig.6 Safe Operating Area