

Silicon NPN Power Transistors

2SC3163

DESCRIPTION

- With TO-220C package
- High breakdown voltage
- High speed switching

PINNING

PIN	DESCRIPTION
1	Base
2	Collector;connected to mounting base
3	Emitter

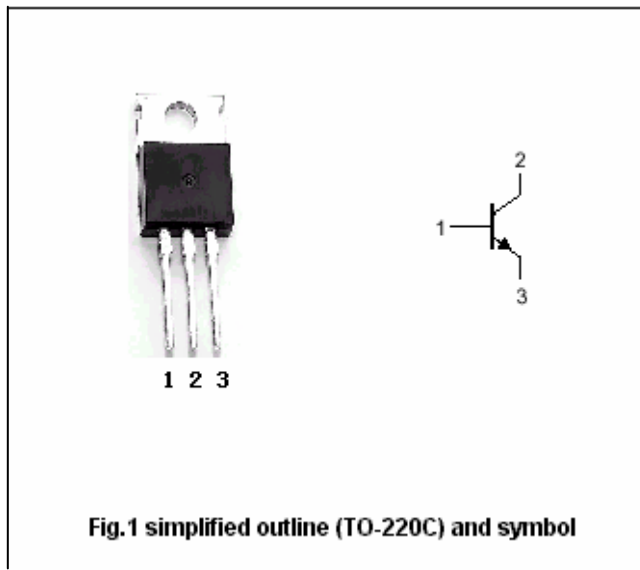

Absolute maximum ratings(Ta=25°C)

SYMBOL	PARAMETER	CONDITIONS	VALUE	UNIT
V _{CBO}	Collector-base voltage	Open emitter	500	V
V _{CEO}	Collector-emitter voltage	Open base	400	V
V _{EBO}	Emitter-base voltage	Open collector	7	V
I _C	Collector current		6	A
I _B	Base current		2	A
P _C	Collector dissipation	T _C =25°C	50	W
T _j	Junction temperature		150	°C
T _{stg}	Storage temperature		-55~150	°C

THERMAL CHARACTERISTICS

SYMBOL	PARAMETER	MAX	UNIT
R _{th j-c}	Thermal resistance junction case	2.5	°C/W

Silicon NPN Power Transistors

2SC3163

CHARACTERISTICS

Tj=25°C unless otherwise specified

SYMBOL	PARAMETER	CONDITIONS	MIN	TYP.	MAX	UNIT
V _{CE0(SUS)}	Collector-emitter sustaining voltage	I _C =100mA ; I _B =0	400			V
V _{CEsat}	Collector-emitter saturation voltage	I _C =3A; I _B =0.3A			1.0	V
V _{BEsat}	Base-emitter saturation voltage	I _C =3A; I _B =0.3A			1.5	V
I _{CEO}	Collector cut-off current	V _{CE} =400V ; I _B =0			100	μA
I _{CBO}	Collector cut-off current	V _{CB} =500V ; I _E =0			100	μA
I _{EBO}	Emitter cut-off current	V _{EB} =7V; I _C =0			100	μA
h _{FE-1}	DC current gain	I _C =3A ; V _{CE} =2V	15			
h _{FE-2}	DC current gain	I _C =6A ; V _{CE} =2V	8			
f _T	Transition frequency	I _C =0.6A ; V _{CE} =10V		20		MHz

Silicon NPN Power Transistors

2SC3163

PACKAGE OUTLINE

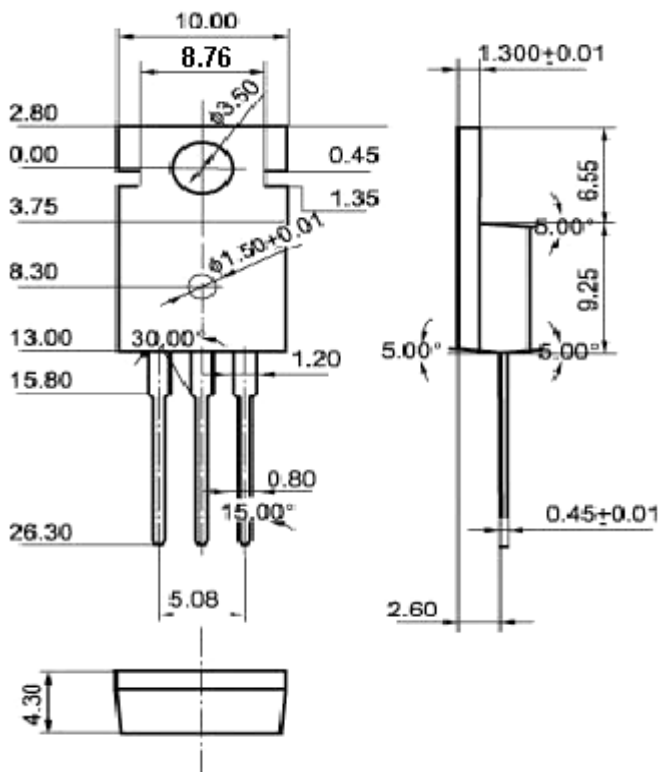

Fig.2 Outline dimensions (unindicated tolerance:±0.10 mm)