

Silicon NPN Power Transistors

2SC2333

DESCRIPTION

- With TO-220C package
- High speed switching
- Low collector saturation voltage

APPLICATIONS

- Switching regulator
- DC-DC converter
- Ultrasonic appliance

PINNING

PIN	DESCRIPTION
1	Base
2	Collector;connected to mounting base
3	Emitter

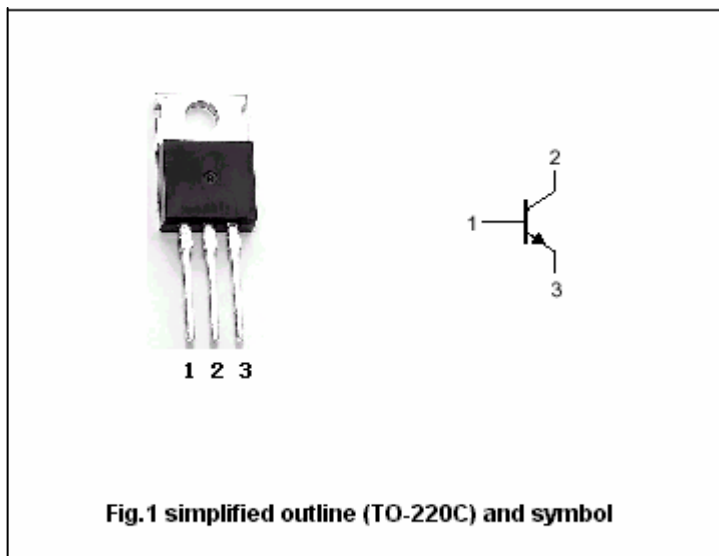

Absolute maximum ratings(Ta=25°C)

SYMBOL	PARAMETER	CONDITIONS	VALUE	UNIT
V <sub>CBO</sub>	Collector-base voltage	Open emitter	500	V
V <sub>CEO</sub>	Collector-emitter voltage	Open base	400	V
V <sub>EBO</sub>	Emitter-base voltage	Open collector	7	V
I <sub>C</sub>	Collector current		2	A
I <sub>CM</sub>	Collector current-peak		4	A
I <sub>B</sub>	Base current		1	A
P <sub>T</sub>	Total power dissipation	T <sub>C</sub> =25°C	15	W
T <sub>j</sub>	Junction temperature		150	°C
T <sub>stg</sub>	Storage temperature		-55~150	°C

## Silicon NPN Power Transistors

## 2SC2333

## CHARACTERISTICS

T<sub>j</sub>=25 °C unless otherwise specified

SYMBOL	PARAMETER	CONDITIONS	MIN	TYP.	MAX	UNIT
V <sub>CEO(SUS)</sub>	Collector-emitter sustaining voltage	I <sub>C</sub> =0.5A; I <sub>B</sub> =0.1A; L=1mA	400			V
V <sub>CEsat</sub>	Collector-emitter saturation voltage	I <sub>C</sub> =0.5A; I <sub>B</sub> =0.1A			1.0	V
V <sub>BEsat</sub>	Base-emitter saturation voltage	I <sub>C</sub> =0.5A; I <sub>B</sub> =0.1A			1.2	V
I <sub>CER</sub>	Collector cut-off current	V <sub>CE</sub> =400V; R <sub>BE</sub> =51Ω; T <sub>a</sub> =125 °C			1.0	mA
I <sub>CEx1</sub>	Collector cut-off current	V <sub>CE</sub> =400V; V <sub>BE(OFF)</sub> =-5.0V			10	μA
I <sub>CEx2</sub>	Collector cut-off current	V <sub>CE</sub> =400V; V <sub>BE(OFF)</sub> =-5.0V T <sub>a</sub> =125 °C			1.0	mA
I <sub>CBO</sub>	Collector cut-off current	V <sub>CB</sub> =400V ; I <sub>E</sub> =0			10	μA
I <sub>EBO</sub>	Emitter cut-off current	V <sub>EB</sub> =5V; I <sub>C</sub> =0			10	μA
h <sub>FE-1</sub>	DC current gain	I <sub>C</sub> =0.1A ; V <sub>CE</sub> =5V	20		80	
h <sub>FE-2</sub>	DC current gain	I <sub>C</sub> =0.5A ; V <sub>CE</sub> =5V	10			
t <sub>on</sub>	Turn on time	I <sub>C</sub> =0.5A; I <sub>B1</sub> =-I <sub>B2</sub> =0.1A R <sub>L</sub> =300Ω; V <sub>CC</sub> =150V			1.0	μs
t <sub>stg</sub>	Storage time				2.5	μs
t <sub>f</sub>	Fall time				1.0	μs

◆ h<sub>FE-1</sub> classifications

M	L	K
20-40	30-60	40-80

Silicon NPN Power Transistors

2SC2333

PACKAGE OUTLINE

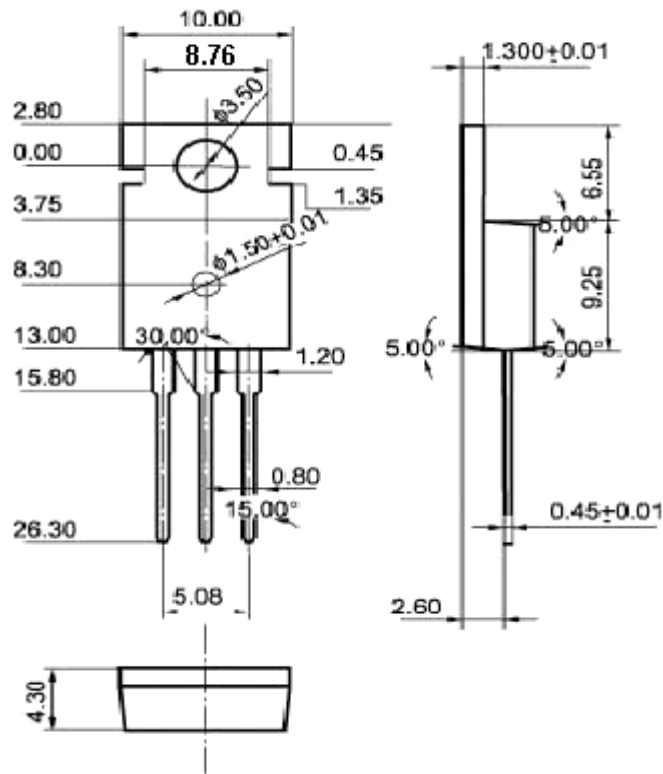

Fig.2 Outline dimensions (unindicated tolerance:  $\pm 0.10$  mm)

Silicon NPN Power Transistors

2SC2333

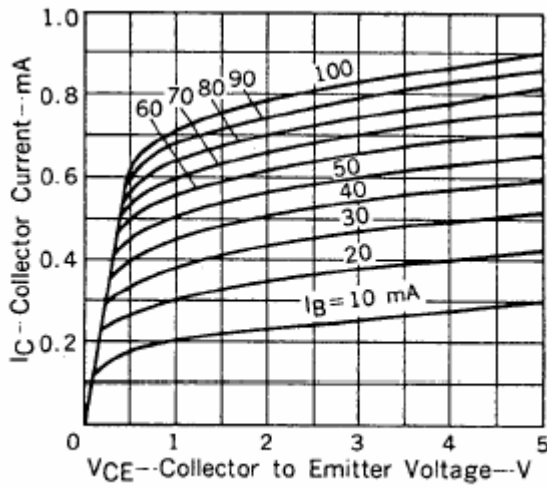

Fig.3 Static Characteristic

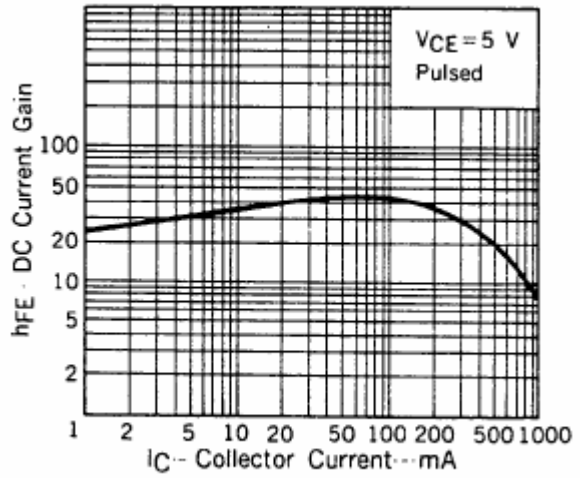

Fig.4 DC current Gain

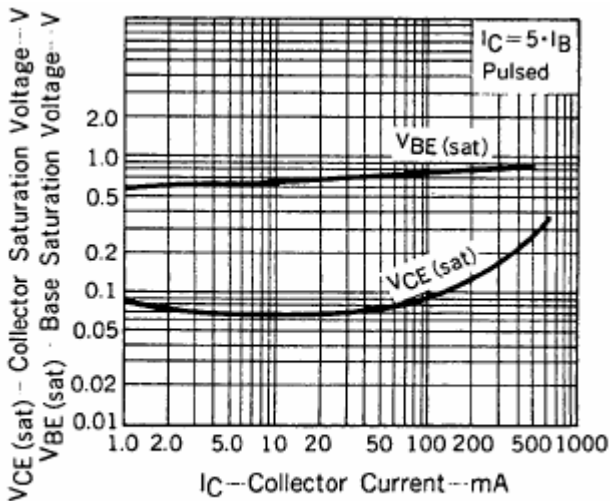

Fig.5 Base-Emitter Saturation Voltage  
Collector-Emitter Saturation Voltage

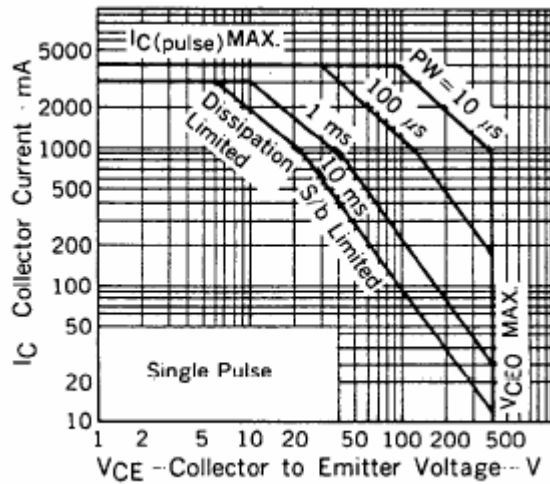

Fig.6 Safe Operating Area