

Silicon NPN Power Transistors

2SC2238 2SC2238A 2SC2238B

DESCRIPTION

- With TO-220 package
- Complement to type 2SA968
- High breakdown votage

APPLICATIONS

- Power amplifier applications
- Driver stage amplifier applications

PINNING

PIN	DESCRIPTION
1	Base
2	Collector;connected to mounting base
3	Emitter

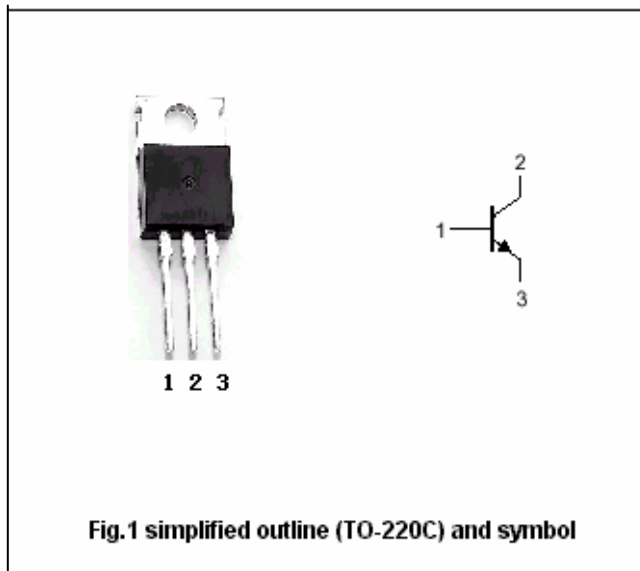

Absolute maximum ratings(Ta=25°C)

SYMBOL	PARAMETER	CONDITIONS	VALUE	UNIT
V _{CBO}	Collector-base voltage	2SC2238	160	V
		2SC2238A	180	
		2SC2238B	200	
V _{CEO}	Collector-emitter voltage	2SC2238	160	V
		2SC2238A	180	
		2SC2238B	200	
V _{EBO}	Emitter-base voltage	Open collector	5	V
I _C	Collector current		1.5	A
I _E	Emitter current		-1.5	A
P _T	Total power dissipation	T _C =25°C	25	W
T _j	Junction temperature		150	°C
T _{stg}	Storage temperature		-55~150	°C

Silicon NPN Power Transistors

2SC2238 2SC2238A 2SC2238B

CHARACTERISTICS

T_j=25°C unless otherwise specified

SYMBOL	PARAMETER	CONDITIONS	MIN	TYP.	MAX	UNIT
V _{(BR)CEO}	Collector-emitter breakdown voltage	2SC2238	160			V
		2SC2238A	180			
		2SC2238B	200			
V _{(BR)EBO}	Emitter-base breakdown voltage	I _E =1mA; I _C =0	5			V
V _{CEsat}	Collector-emitter saturation voltage	I _C =500mA; I _B =50mA			1.5	V
V _{BE}	Base-emitter on voltage	I _C =500mA; V _{CE} =5V			1.0	V
I _{CBO}	Collector cut-off current	V _{CB} =160V; I _E =0			1.0	μA
I _{EBO}	Emitter cut-off current	V _{EB} =5V; I _C =0			1.0	μA
h _{FE}	DC current gain	I _C =100mA; V _{CE} =5V	70		240	
C _{ob}	Output capacitance	I _E =0; V _{CB} =10V, f=1MHz		25		pF
f _T	Transition frequency	I _C =100mA; V _{CE} =10V		100		MHz

◆ h_{FE} Classifications

O	Y
70-140	120-240

Silicon NPN Power Transistors

2SC2238 2SC2238A 2SC2238B

PACKAGE OUTLINE

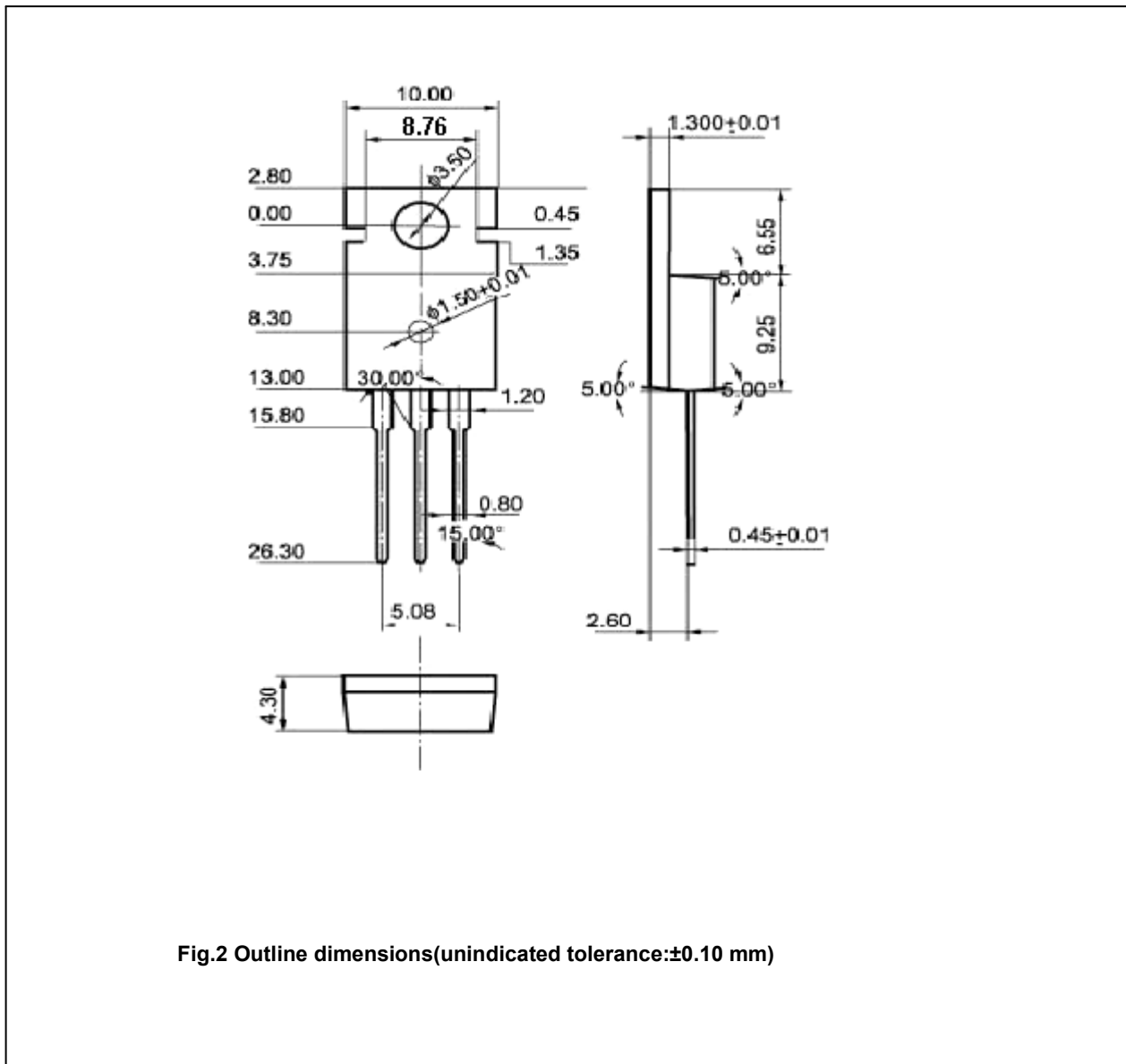

Fig.2 Outline dimensions(unindicated tolerance:±0.10 mm)