



2SB647

PNP EPITAXIAL SILICON TRANSISTOR

SILICON PNP EPITAXIAL

■ DESCRIPTION

The UTC **2SB647** is a PNP epitaxial silicon transistor, which can be used as a low frequency power amplifier.

■ APPLICATION

* Low frequency power amplifier

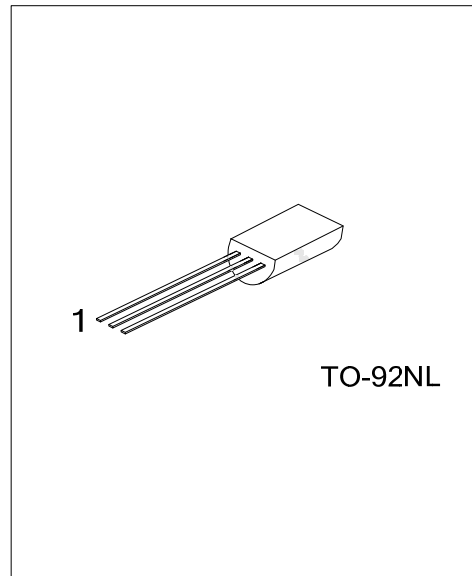

■ ORDERING INFORMATION

Ordering Number		Package	Pin Assignment			Packing
Lead Free	Halogen Free		1	2	3	
2SB647L-x-T9N-B	2SB647G-x-T9N-B	TO-92NL	E	C	B	Tape Box
2SB647L-x-T9N-K	2SB647G-x-T9N-K	TO-92NL	E	C	B	Bulk

<p>2SB647G-x-T9N-B</p>	<p>(1) Packing Type (2) Package Type (3) Rank (4) Green Package</p>	<p>(1) B: Tape Box, K: Bulk (2) T9N: TO-92NL (3) refer to CLASSIFICATION OF h_{FE1} (4) G: Halogen Free and Lead Free, L: Lead Free</p>
------------------------	---	--

■ MARKING

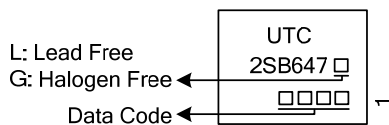

■ ABSOLUTE MAXIMUM RATINGS (T_A=25°C, unless otherwise specified)

PARAMETER	SYMBOL	RATINGS	UNIT
Collector-Base Voltage	V _{CBO}	-120	V
Collector-Emitter Voltage	V _{CEO}	-80	V
Emitter-Base Voltage	V _{EBO}	-6	V
Collector Current	I _C	-1	A
Collector Peak Current	I _{CP}	-2	A
Collector Power Dissipation	P _C	0.9	W
Junction Temperature	T _J	150	°C
Storage Temperature	T _{STG}	-55 ~ +150	°C

Notes: 1. Absolute maximum ratings are those values beyond which the device could be permanently damaged.

Absolute maximum ratings are stress ratings only and functional device operation is not implied.

2. PW≤10ms, Duty cycle≤20%

■ ELECTRICAL CHARACTERISTICS (T_A=25°C, unless otherwise specified)

PARAMETER	SYMBOL	TEST CONDITIONS	MIN	TYP	MAX	UNIT
Collector-Base Breakdown Voltage	BV _{CBO}	I _C = -10μA, I _E =0	-120			V
Collector-Emitter Breakdown Voltage	BV _{CEO}	I _C = -1mA, R _{BE} =∞	-80			V
Emitter-Base Breakdown Voltage	BV _{EBO}	I _E = -10μA, I _C =0	-6			V
Collector Cut-Off Current	I _{CBO}	V _{CB} = -120V, I _E =0			-500	nA
Emitter Cutoff Current	I _{EBO}	V _{EB} =-6V, I _C =0			-500	nA
DC Current Transfer Ratio	h _{FE1}	V _{CE} = -5V, I _C = -150mA (note)	60		320	
	h _{FE2}	V _{CE} = -5V, I _C = -500mA (note)	40			
Collector-Emitter Saturation Voltage	V _{CE(SAT)}	I _C = -500mA, I _B = -50mA (note)			-0.5	V
Base to Emitter Saturation Voltage	V _{BE(SAT)}	I _C =-500mA, I _B =-50mA			-1.1	V
Gain Bandwidth Product	f _T	V _{CE} = -5V, I _C = -150mA		140		MHz
Collector Output Capacitance	C _{ob}	V _{CB} = -10V, I _E =0, f=1MHz		20		pF

■ CLASSIFICATION OF h_{FE1}

RANK	B	C	D
RANGE	60-120	100-200	160-320

TYPICAL CHARACTERISTICS

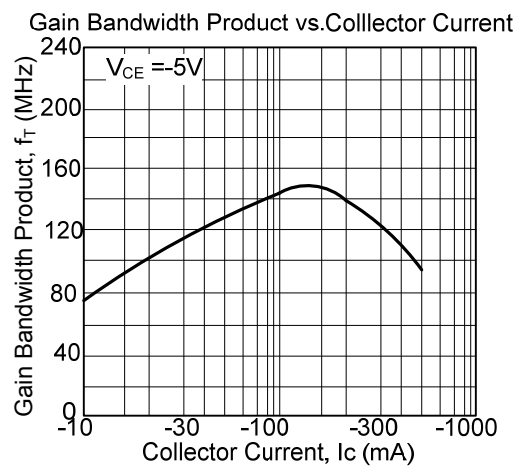
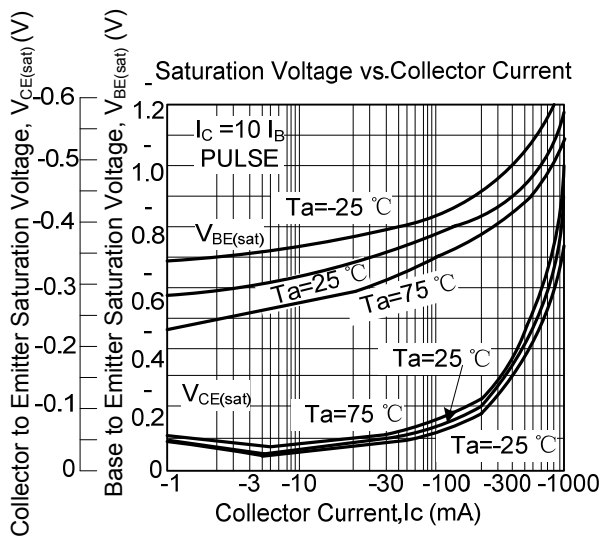
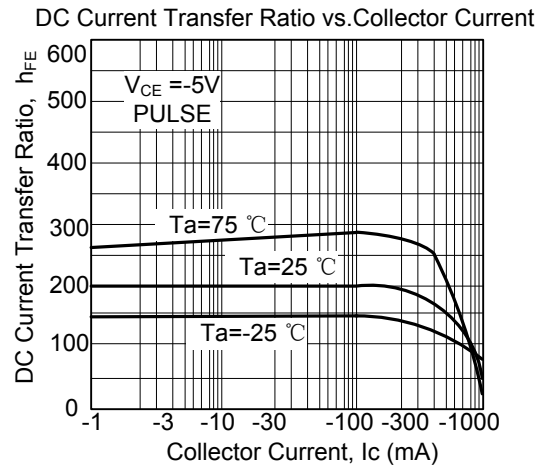
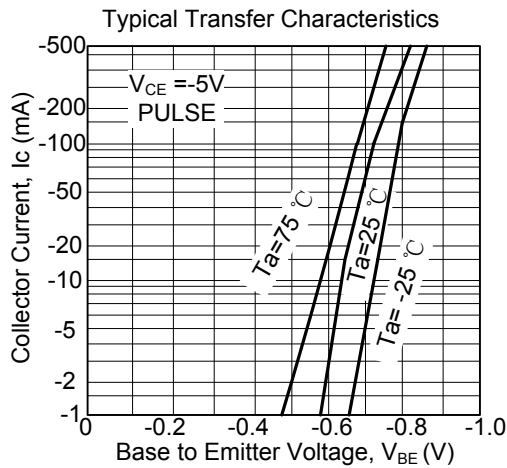
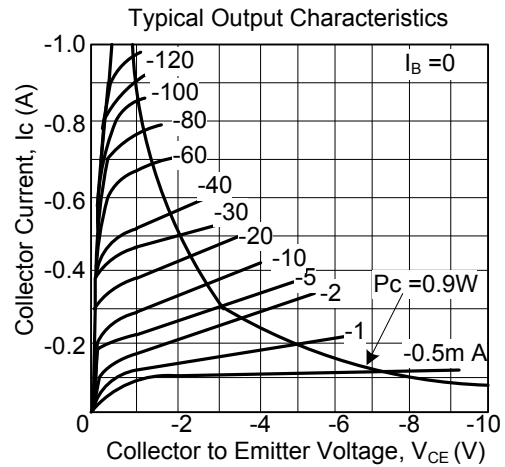
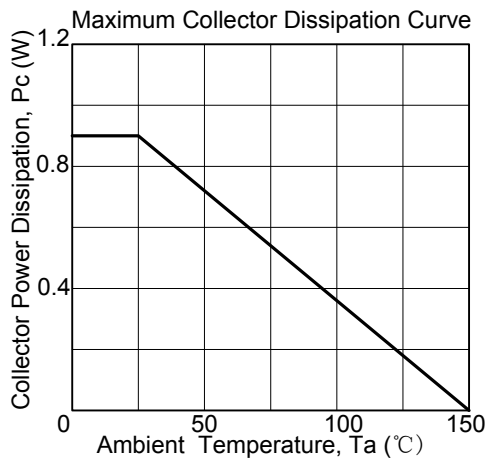

■ TYPICAL CHARACTERISTICS (Cont.)

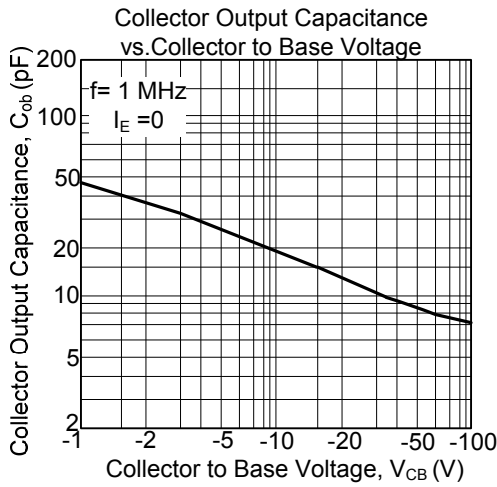

UTC assumes no responsibility for equipment failures that result from using products at values that exceed, even momentarily, rated values (such as maximum ratings, operating condition ranges, or other parameters) listed in products specifications of any and all UTC products described or contained herein. UTC products are not designed for use in life support appliances, devices or systems where malfunction of these products can be reasonably expected to result in personal injury. Reproduction in whole or in part is prohibited without the prior written consent of the copyright owner. The information presented in this document does not form part of any quotation or contract, is believed to be accurate and reliable and may be changed without notice.