

isc Silicon PNP Power Transistors

2SB536

DESCRIPTION

- Collector-Emitter Breakdown Voltage-
: $V_{(BR)CEO} = -120V$ (Min.)
- Complement to Type 2SD381

APPLICATIONS

- Audio frequency power amplifier, low speed switching.
- Suitable for driver of 60~100 watts audio amplifier.

ABSOLUTE MAXIMUM RATINGS($T_a=25^{\circ}C$)

SYMBOL	PARAMETER	VALUE	UNIT
V_{CBO}	Collector-Base Voltage	-130	V
V_{CEO}	Collector-Emitter Voltage	-120	V
V_{EBO}	Emitter-Base Voltage	-5	V
I_C	Collector Current-Continuous	-1.5	A
I_{CM}	Collector Current-Peak	-3.0	A
I_B	Base Current	-0.3	A
P_C	Collector Power Dissipation@ $T_C=25^{\circ}C$	20	W
	Collector Power Dissipation@ $T_a=25^{\circ}C$	1.5	
T_J	Junction Temperature	150	$^{\circ}C$
T_{stg}	Storage Temperature	-55~150	$^{\circ}C$

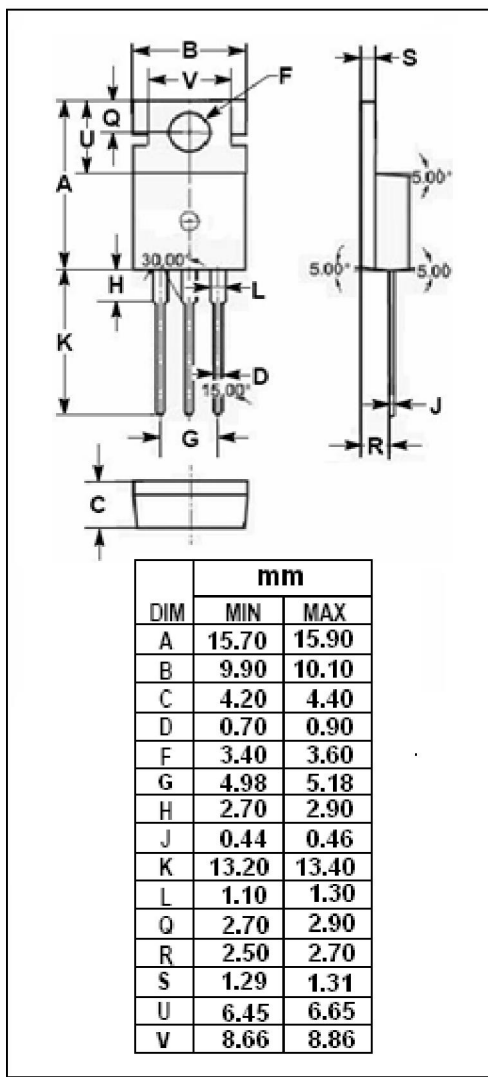
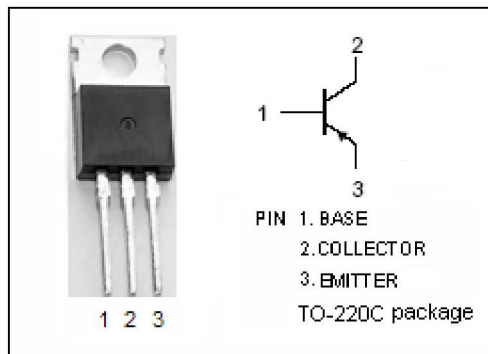

isc Silicon PNP Power Transistors**2SB536****ELECTRICAL CHARACTERISTICS** $T_C=25^{\circ}\text{C}$ unless otherwise specified

SYMBOL	PARAMETER	CONDITIONS	MIN	TYP.	MAX	UNIT
$V_{CE(sat)}$	Collector-Emitter Saturation Voltage	$I_C = -1\text{A}; I_B = -0.1\text{A}$			-2.0	V
$V_{BE(sat)}$	Base-Emitter Saturation Voltage	$I_C = -1\text{A}; I_B = -0.1\text{A}$			-1.5	V
I_{CBO}	Collector Cutoff Current	$V_{CB} = -120\text{V}; I_E = 0$			-1.0	μA
I_{EBO}	Emitter Cutoff Current	$V_{EB} = -3\text{V}; I_C = 0$			-1.0	μA
h_{FE-1}	DC Current Gain	$I_C = -5\text{mA}; V_{CE} = -5\text{V}$	25			
h_{FE-2}	DC Current Gain	$I_C = -0.3\text{A}; V_{CE} = -5\text{V}$	40		250	
C_{OB}	Output Capacitance	$I_E = 0; V_{CB} = -10\text{V}; f = 0.1\text{MHz}$		35		pF
f_T	Current-Gain—Bandwidth Product	$I_C = -0.1\text{A}; V_{CE} = -5\text{V}$		40		MHz

◆ **h_{FE} Classifications**

N	M	L	K
40-80	60-120	80-160	120-250