

FEATURES

- Plastic package has Underwriters Laboratory Flammability Classification 94V-0
- Metal silicon junction ,majority carrier conduction
- Guard ring for overvoltage protection
- Low power loss ,high efficiency
- High current capability ,low forward voltage drop
- High surge capability
- For use in low voltage ,high frequency inverters, free wheeling ,and polarity protection applications
- High temperature soldering guaranteed:260 C/10 seconds at terminals
- Component in accordance to RoHS 2002/95/EC and WEEE 2002/96/EC

MECHANICAL DATA

- *Case:* JEDEC DO-201AD molded plastic body
- *Terminals:* Plated axial leads, solderable per MIL-STD-750,method 2026
- *Polarity:* color band denotes cathode end
- *Mounting Position:* Any
- *Weight:* 0.041ounce, 1.15 grams

DO-201AD

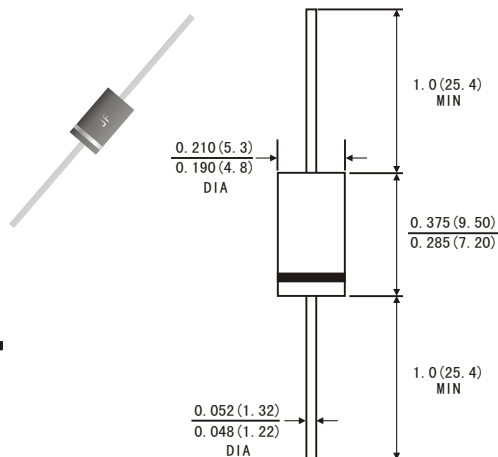

Dimensions in inches and (millimeters)

MAXIMUM RATINGS AND ELECTRICAL CHARACTERISTICS

(Ratings at 25°C ambient temperature unless otherwise specified ,Single phase ,half wave ,resistive or inductive load. For capacitive load,derate by 20%.)

	Symbols	12SQ045	Units
Maximum repetitive peak reverse voltage	V _{RRM}	45	Volts
Maximum RMS voltage	V _{RMS}	32	Volts
Maximum DC blocking voltage	V _{DC}	45	Volts
Maximum average forward rectified current 0.375"(9.5mm) lead length(see fig.1)	I _(AV)	12.0	Amps
Peak forward surge current 8.3ms single half sine-wave superimposed on rated load (JEDEC method at rated T _j)	I _{FSM}	150.0	Amps
Maximum instantaneous forward voltage at 12.0 A(Note 1)	V _F	0.55	Volts
Maximum instantaneous reverse current at rated DC blocking voltage(Note 1)	I _R	T _a = 25°C	0.2
		T _a = 100°C	50
Typical junction capacitance(Note 3)	C _J	400	pF
Typical thermal resistance (Note 2)	R _{θJC}	2.5	°C/W
Operating junction temperature range at reduced reverse voltage V _R <= 80%V _{RRM} V _R <= 50%V _{RRM} in DC forward model	T _J	-65 to+150 -65 to+175 -65 to+200	°C
Storage temperature range	T _{STG}	-65 to+200	°C

Notes: 1.Pulse test: 300μ s pulse width,1% duty cycle

2.Thermal resistance from junction to case

3.Measured at 1MHz and reverse voltage of 4.0 volts

RATINGS AND CHARACTERISTIC CURVES 12SQ045

FIG.1-FORWARD CURRENT DERATING CURVE

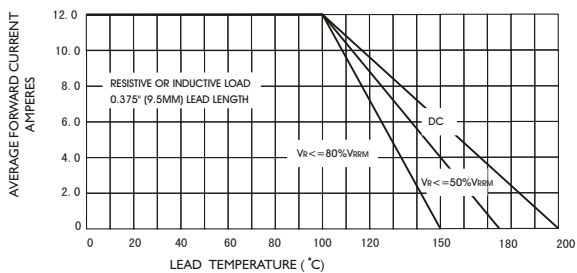

FIG.2-MAXIMUM NON-REPETITIVE PEAK FORWARD SURGE CURRENT

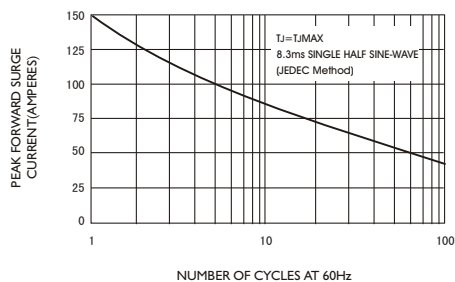

FIG.3-TYPICAL INSTANTANEOUS FORWARD CHARACTERISTICS

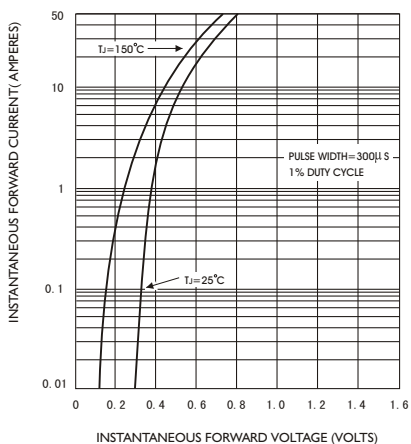

FIG.4-TYPICAL REVERSE CHARACTERISTICS

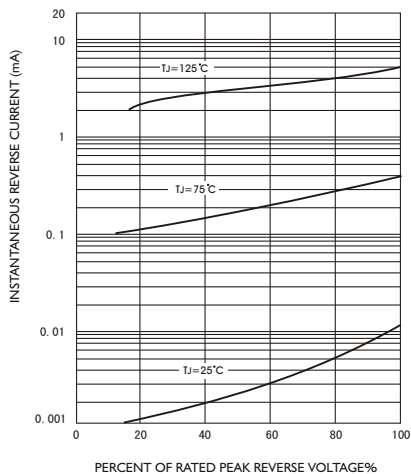

FIG.5-TYPICAL JUNCTION CAPACITANCE

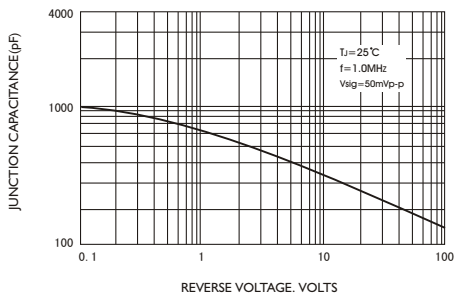

FIG.6-TYPICAL TRANSIENT THERMAL IMPEDANCE

