

ORDERING INFORMATION

Device	Temperature Range	Package
MC1327P	-20°C to +75°C	Plastic DIP

MC1327

Advance Information

DUAL DOUBLY BALANCED CHROMA DEMODULATOR WITH RGB MATRIX, PAL SWITCH, AND CHROMA DRIVER STAGES

... a monolithic device designed for use in solid-state color television receivers.

- Good Chroma Sensitivity — 0.28 V_{p-p} Input Typical for 5.0 V_{p-p} Output
- Low Differential Output DC Offset Voltage — 0.6 V Maximum
- Differential DC Temperature Stability — 0.7 mV/°C
- High Blue Output Voltage Swing — 10 V_{p-p} Typical
- Blanking Input Provided
- Luminance Bandwidth Greater than 5.0 MHz

DUAL DOUBLY BALANCED CHROMA DEMODULATOR for PAL or NTSC

SILICON MONOLITHIC INTEGRATED CIRCUIT

P SUFFIX
PLASTIC PACKAGE
CASE 646-05

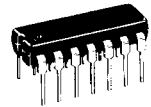
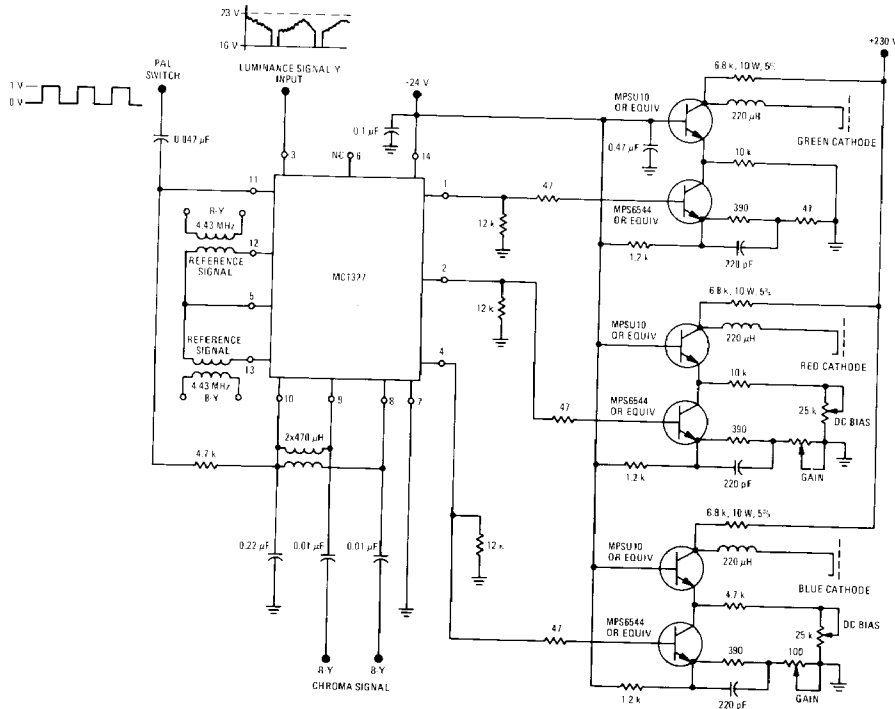

FIGURE 1 — TYPICAL APPLICATION CIRCUIT



This document contains information on a new product. Specifications and information herein are subject to change without notice.

MAXIMUM RATINGS ($T_A = +25^\circ\text{C}$ unless otherwise noted)

Rating	Value	Unit
Power Supply Voltage	30	Vdc
Chroma Signal Input Voltage	5.0	Vpk
Reference Signal Input Voltage	5.0	Vpk
Minimum Load Resistance	3.0	k ohms
Luminance Input Voltage	12	Vp-p
Blanking Input Voltage	7.0	Vp-p
Power Dissipation (Package Limitation) Plastic Packages Derate above $T_A = +25^\circ\text{C}$	625 5.0	mW mW/ $^\circ\text{C}$
Operating Temperature Range (Ambient)	-20 to +75	$^\circ\text{C}$
Storage Temperature Range	-65 to +150	$^\circ\text{C}$

ELECTRICAL CHARACTERISTICS ($V_{CC} = 24$ Vdc, $R_L = 3.3$ k ohms, $T_A = +25^\circ\text{C}$ unless otherwise noted)

Characteristic	Pin No.	Min	Typ	Max	Unit
----------------	---------	-----	-----	-----	------

STATIC CHARACTERISTICS

Quiescent Output Voltage (See Figure 2)	1,2,4	13.2	14.5	15.8	Vdc
Quiescent Input Current from Supply (Figure 2) ($R_L = \infty$) ($R_L = 3.3$ k ohms)		— 16	7.5 19	— 26	mA
Reference Input DC Voltage (Figure 2)	5,12,13	—	6.2	—	Vdc
Chroma Reference Input DC Voltage (Figure 2)	8,9,10	—	3.4	—	Vdc
Differential Output Voltage (See Note 1 and Figure 2)	1,2,4	—	0.3	0.6	Vdc
Differential Output Voltage Temperature Coefficient (See Note 1 and Figure 2) (+25 $^\circ\text{C}$ to +65 $^\circ\text{C}$)	1,2,4	—	0.7	—	mV/ $^\circ\text{C}$
Output Voltage Temperature Coefficient (See Note 1 and Figure 2) (+25 $^\circ\text{C}$ to +65 $^\circ\text{C}$)	1,2,4	—	+0.5	± 5.0	mV/ $^\circ\text{C}$

DYNAMIC CHARACTERISTICS ($V_{CC} = 24$ Vdc, $R_L = 3.3$ k ohms, Reference Input Voltage = 1.0 Vp-p, $T_A = +25^\circ\text{C}$ unless otherwise noted)

Blue Output Voltage Swing (See Note 2 and Figure 3)	4	8.0	10	—	Vp-p
Chroma Input Voltage (B Output = 5.0 Vp-p) (See Note 3 and Figure 3)	8	—	280	550	mVp-p
Luminance Input Resistance	3	100	—	—	k Ω
Luminance Gain From Pin 3 to Outputs (@ dc) (@ 5.0 MHz, reference at 100 kHz)	1,2,4	—	0.95 -1.8	—	— dB
Differential Luminance Gain, RGB Outputs (@ 5.0 MHz)		—	0.3	—	dB
Blanking Input Resistance (1.0 Vdc) (0 Vdc)	6	—	1.1 75	—	k Ω
Detected Output Voltage (Adjust B Output to 5.0 Vp-p, Luminance Voltage = 23 V) (See Note 4)	4	—	—	—	Vp-p
G Output	1	1.4	1.8	2.2	
R Output	2	2.5	2.9	3.3	
PAL Switch Operating Voltage Range (7.8 kHz Square Wave)	11	0.3	—	3.0	Vp-p
R-Y Output dc Offset with PAL Switch Operation		—	—	100	mVdc
Demodulator Unbalance Voltage (no Chroma Input Voltage and normal Reference Signal Input Voltage)	1,2,4	—	200	300	mVp-p
Residual Carrier and Harmonics Output Voltage (with Input Signal Voltage, normal Reference Signal Voltage and B Output = 5.0 Vp-p)	1,2,4	—	0.6	1.0	Vp-p
Reference Input Resistance (Chroma Input = 0)	12,13	—	2.0	—	k Ω
Reference Input Capacitance (Chroma Input = 0)	12,13	—	6.0	—	pF
Chroma Input Resistance	8,9,10	—	2.0	—	k Ω
Chroma Input Capacitance	8,9,10	—	2.0	—	pF

NOTES:

- Chroma Input Signal Voltage = 0 and normal Reference Input Signal Voltage = 1.0 Vp-p.
- With normal Reference Input Signal Voltage, adjust Chroma Input Signal Voltage to 1.2 Vp-p.
- With normal Reference Input Signal Voltage, adjust Chroma Input Signal Voltage until the Blue Output Voltage = 5.0 Vp-p.
- With normal Reference Input Signal Voltage, adjust Chroma Input Signal Voltage until the Blue Output Voltage = 5.0 Vp-p. At this point, the Red and Green voltages will fall within the specified limits.

TEST CIRCUITS

($V_{CC} = 24 \text{ Vdc}$, $R_L = 3.3 \text{ kilohms}$, $T_A = +25^\circ\text{C}$ unless otherwise noted)

FIGURE 2 – DC OUTPUT VOLTAGE TEST CIRCUIT WITH NORMAL REFERENCE INPUT VOLTAGE (B, R, AND G)

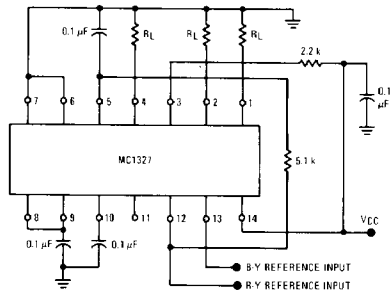
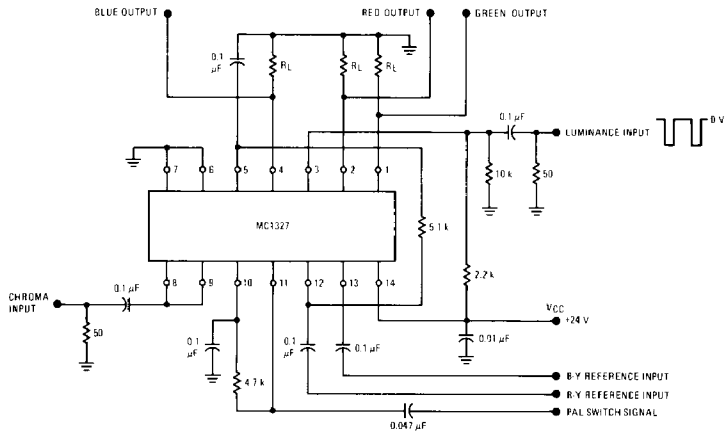
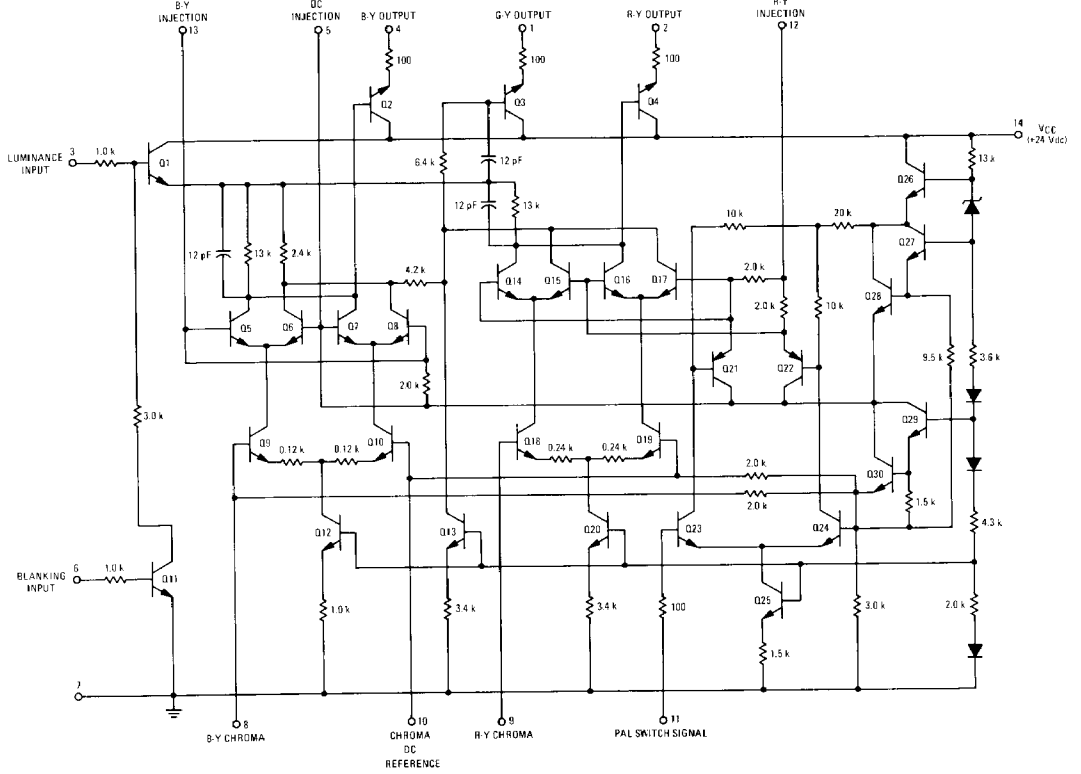

FIGURE 3 – DYNAMIC TEST CIRCUIT



CHROMA DEMODULATOR



10