

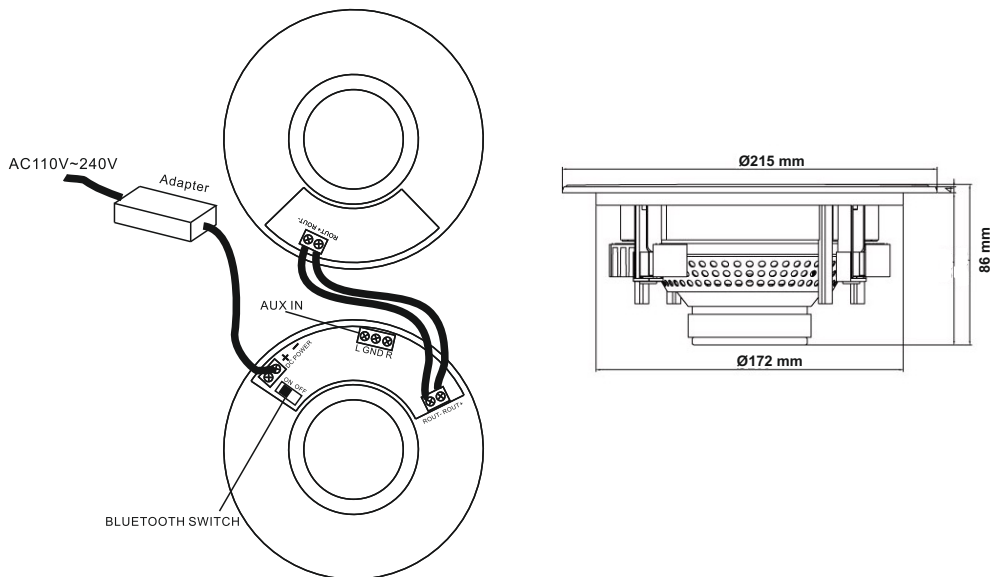

MAB 40A

User Manual/Manual de Uso

CEILING SPEAKERS with BLUETOOTH



- Use the included power supply to feed the active device.
- Select the switch to OFF position and connect a LINE level signal in AUX IN.
- Select the switch in ON position and send music from an external device like smartphone through Bluetooth protocol.

MODEL	ACTIVE	PASSIVE
Elements	5.25" woofer + 1" TWT	5.25" woofer + 1" TWT
Power amplifier	15W + 15W	-----
Inputs	AUX in /BLUETOOTH interface	Loudspeaker contacts
Outputs	LINK to passive device	-----
Frequency response	80 Hz - 20 kHz	80 Hz - 20 kHz
Mounting hole	Ø215x 86 mm	Ø215x 86 mm
Dimensions	Ø172 mm	Ø172 mm
Material	Metal (grille) ABS (enclosure)	Metal (grille) ABS (enclosure)

ALTAVOCES DE TECHO con BLUETOOTH

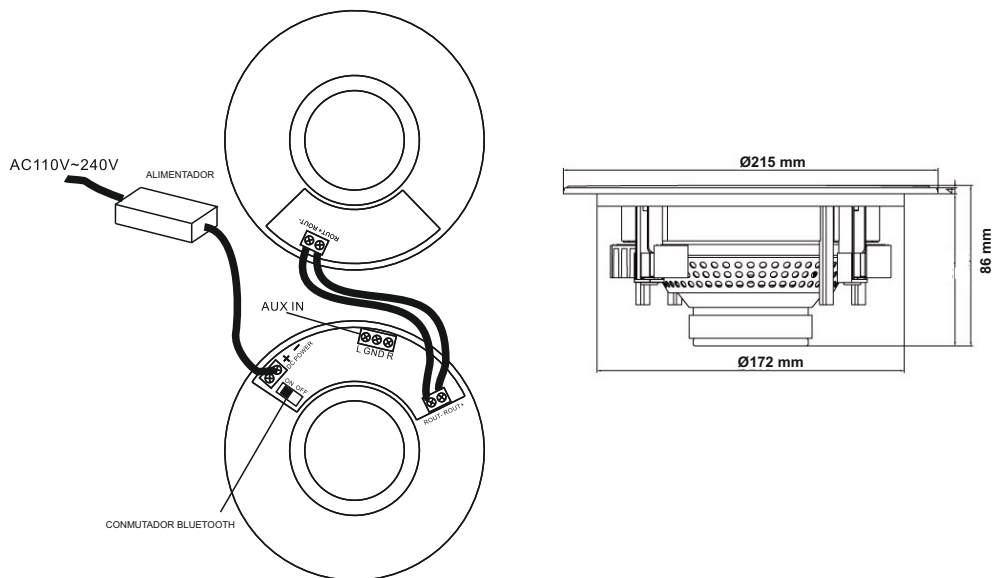

- Utilice el alimentador externo incluido para alimentar la unidad.
- Seleccione el conmutador en la posición OFF y conecte una señal de nivel LINE en la toma AUX IN.
- Seleccione el conmutador en la posición ON y envíe música desde un dispositivo externo como teléfonos móviles a través de protocolo Bluetooth.

MODELO	ACTIVO	PASIVO
Elementos	5.25" woofer + 1" TWT	5.25" woofer + 1" TWT
Potencia del amplificador	15W + 15W	-----
Entradas	AUX in / interfaz BLUETOOTH	Contactos de altavoz
Salidas	LINK al dispositivo pasivo	-----
Respuesta en frecuencia	80 Hz - 20 kHz	80 Hz - 20 kHz
Diámetro de montaje	$\varnothing 215 \times 86$ mm	$\varnothing 215 \times 86$ mm
Dimensiones	$\varnothing 172$ mm	$\varnothing 172$ mm
Material	Metal (rejilla) ABS (recinto)	Metal (rejilla) ABS (recinto)

EQUIPSON, S.A.

Avda. El Saler, 14 - Pol. Ind. L'Alteró
46460 - Silla (Valencia) Spain
Tel. +34 96 121 63 01 Fax + 34 96 120 02 42
www.markpro.es / equipson@equipson.es

