

Small Signal Diode

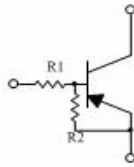

**DTA114 EM/EE/EUA/ECA/ESA
PNP Digital Transistor**

Features

- ◇ Built-in bias resistors enable the configuration of an inverter circuit without connecting external input resistor (see equivalent circuit).
- ◇ The bias resistors consist of thin-film resistors with complete isolation to allow negative biasing of the input. They also have the advantage of almost completely eliminating parasitic effects.
- ◇ Only the on/off conditions need to be set for operation, making device design easy.
- ◇ Green compound (Halogen free) with suffix "G" on packing code and prefix "G" on date code.

• Equivalent Circuit

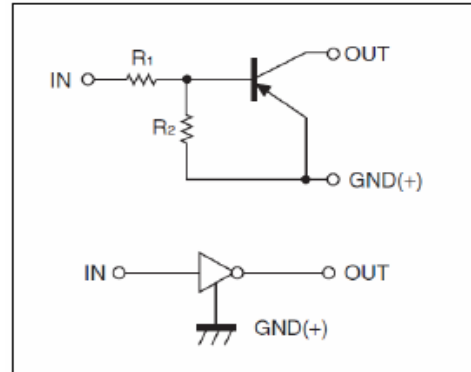

Ordering Information

Package	Part No.	Packing	Marking
SOT-723	DTA114 EM	8K / 7" Reel	14
SOT-523	DTA114 EE	3K / 7" Reel	14
SOT-323	DTA114 EUA	3K / 7" Reel	14
SOT-23	DTA114 ECA	3K / 7" Reel	14
TO-92S	DTA114 ESA	3K / 7" Reel	

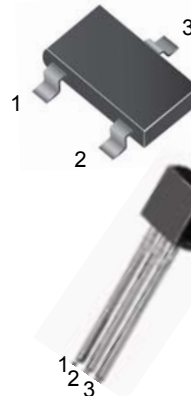

**SOT-723/SOT-523
SOT-323/SOT-23**

- 1.IN
- 2.GND
- 3.OUT

TO-92S

- 1.GND
- 2.OUT
- 3.IN

Maximum Ratings and Electrical Characteristics

Rating at 25°C ambient temperature unless otherwise specified.

Type Number	Symbol	Value					Units
		EM	EE	EUA	ECA	ESA	
Power Dissipation	PD	100	150	200		300	mW
Supply Voltage	V _{CC}	-50					V
Input Voltage	V _{IN}	-40 ~ 10					V
Output Current	I _O	-50					mA
Peak Collector Current	I _{C(MAX)}	-100					
Junction and Storage Temperature Range	T _J , T _{STG}	-55 to + 150					°C

Notes: 1. Valid provided that electrodes are kept at ambient temperature

Parameter	Symbol	Min	Typ	Max	Condition	Unit
Input Voltage	V _{I(on)}			-3	V _{CC} =-5V, I _O =-100μA	V
	V _{I(off)}	-0.5			V _O =-0.3V, I _O =-10mA	
Output Voltage	V _{O(on)}			-0.3	I _O /I _I =-10mA/-5mA	V
Input Current	I _I			-0.88	V _I =-5V	mA
Output Current	I _{O (off)}			-0.5	V _{CC} =-50V, V _I =0	μA
DC Current Gain	G _I	30			V _O =-5V, I _O =-5mA	
Input Resistance	R ₁	7	10	13		KΩ
Resistance Ratio	R ₂ /R ₁	0.8	1	1.2		
Transition Frequency	f _T		250		V _O =-10V, I _O =-5mA, f=100MHz	MHz

DTA114 EM/EE/EUA/ECA/ESA PNP Digital Transistor

SOT-23

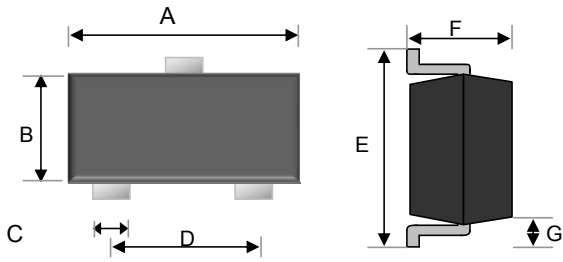

Dimensions	Unit (mm)		Unit (inch)	
	Min	Max	Min	Max
A	2.80	3.00	0.11	0.12
B	1.20	1.40	0.05	0.06
C	0.30	0.50	0.01	0.02
D	1.80	2.00	0.07	0.08
E	2.25	2.55	0.09	0.10
F	0.90	1.20	0.04	0.04
G	0.550 REF		0.022 REF	

SOT-323

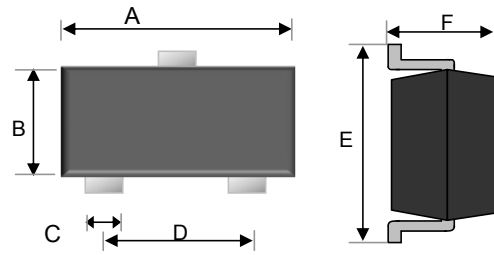

Dimensions	Unit (mm)		Unit (inch)	
	Min	Max	Min	Max
A	1.90	2.10	0.07	0.08
B	1.15	1.35	0.05	0.05
C	0.25	0.35	0.01	0.01
D	1.20	1.40	0.05	0.06
E	2.00	2.20	0.08	0.09
F	0.80	1.00	0.03	0.04

SOT-523

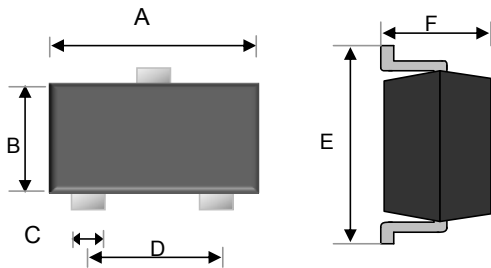

Dimensions	Unit (mm)		Unit (inch)	
	Min	Max	Min	Max
A	1.50	1.70	0.06	0.07
B	0.70	0.80	0.03	0.03
C	0.25	0.35	0.01	0.01
D	0.90	1.10	0.04	0.04
E	1.50	1.70	0.06	0.07
F	0.70	0.90	0.03	0.04

SOT-723

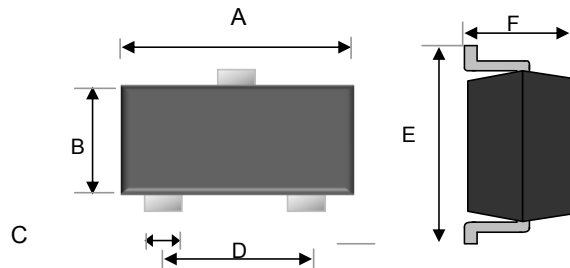

Dimensions	Unit (mm)		Unit (inch)	
	Min	Max	Min	Max
A	1.15	1.25	0.05	0.05
B	0.75	0.85	0.03	0.03
C	0.17	0.27	0.01	0.01
D	0.8 TYP		0.31 TYP	
E	1.15	1.25	0.05	0.05
F		0.50		0.02

TO-92S

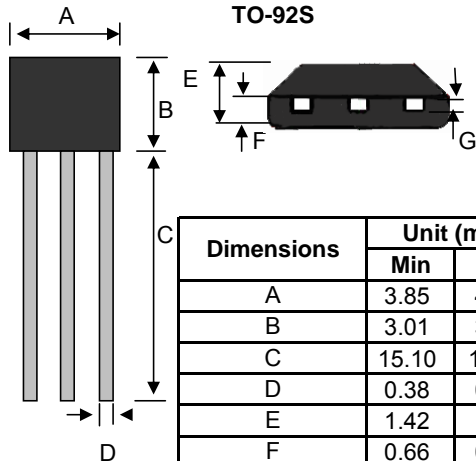

Dimensions	Unit (mm)		Unit (inch)	
	Min	Max	Min	Max
A	3.85	4.15	0.15	0.16
B	3.01	3.31	0.12	0.13
C	15.10	15.50	0.59	0.61
D	0.38	0.55	0.01	0.02
E	1.42	1.62	0.06	0.06
F	0.66	0.86	0.03	0.03
G	0.36	0.51	0.01	0.02

Mouser Electronics

Authorized Distributor

Click to View Pricing, Inventory, Delivery & Lifecycle Information:

Taiwan Semiconductor:

[DTA114ECA RF](#) [DTA114EE RK](#) [DTA114ESA](#) [DTA114EUA RR](#) [DTA114TCA RF](#) [DTA114TE RK](#) [DTA114TSA](#)
[DTA114TUA RR](#) [DTA114YCA RF](#) [DTA114YE RK](#) [DTA114YSA](#) [DTA114YUA RR](#)